

UNICARRIERS[®]

□ FORKLIFT □

FK Series



Engine Powered Forklifts

EPA Tier 4 Diesel

4,000 - 7,000 lbs. Capacities | Pneumatic Tire



S P E C I F I C A T I O N S

OPERATOR COMFORT & CONTROL

The FK Series offers a variety of operator conveniences for greater productivity including a standard full suspension seat for enhanced shock absorption. The seat includes lumbar support adjustment, weight-adjustment plus operator restraint armrests. Non-cinching seat belt provides greater range of movement. A spacious operator compartment provides generous foot, leg and head room for a variety of driver sizes.

Enhanced comfort results from the FK Series' Operator Comfort System, which includes a rubber floor mat, pedals mounted to the chassis frame, and rubber shock absorbers located throughout the vehicle to reduce vibration from the engine and transmission. For additional vibration reduction, FK Series models include an automotive-type floating powertrain design, which incorporates four rubber engine/transmission supports.

The FK Series' tilt-adjustable steering wheel helps the operator quickly find his or her ideal driving position, while its compact design offers enhanced control and handling. Automotive-style light and turn signal levers simplify repetitive actions allowing the operator to focus on the job. Low profile design provides ample head clearance. An optional swivel seat pivots 15° to the left and right, for more comfortable reverse driving*.

Hydrostatic power steering system reduces operator effort for easier maneuvering and less fatigue. Exclusive single hydraulic control lever design combines lift and tilt operations into one fluid motion for greater productivity. Separate control levers are available at no charge. An optional auto-tilt leveling system assists operator during mast/fork positioning.

ENHANCED WORK ENVIRONMENT

Several standard features are included in the FK Series to deliver a more comfortable and productive work environment for the operator and those in the surrounding area.

The FK Series' Operator Presence System, with seat-actuated power interrupt, incorporates a mast-lock which automatically locks lift and tilt operations when the operator leaves the seat, and a return to neutral feature to minimize forklift movement if the operator leaves the seat while the lift truck is still in gear. This presence system also includes audible and visual warnings if either the seat belt is not engaged, or when the parking brake has not been applied prior to the operator exiting the compartment.

For easy entry/exit, an assist grip, combined with a replaceable metal traction plate bolted to the truck's wide, low entry step, provide the operator with comfortable footing and grip for this often repeated task.

UniCarriers' own GCT ZD30 engine offers extremely low noise levels at the operator's ear during idle and at maximum travel speeds. An optional travel speed control feature is available to regulate high or low maximum travel speed settings, while the controlled acceleration's Economy Mode adjusts throttle sensitivity to increase fuel efficiency, extend drivetrain life and reduce excessive tire wear.

Maintenance-free cushioned stability control, with rubber dampers located between rear axle and body, enhance lateral stability under normal driving conditions.

DURABLE DESIGN FEATURES

The FK Series is built for rugged applications, incorporating a robust mast, strong frame and thick steel fenders.

The FK's superior cooling system consists of an oversized fan and wide cooling outlet, for enhanced airflow. Plus, a heavy-duty radiator, with transmission oil cooler, rubber mounted to reduce flexing and absorb vibration for enhanced reliability. Its improved cooling capacity translates into dependable cooling efficiency under heavy usage or high ambient temperatures. A heavy-duty steer axle protects the steer cylinder from damage, while steer cylinder boot covers keep out dirt and debris.

Lift cylinders include oil return piping for reduced heat generation. The counterweight is designed to deflect cooling airflow down and away from the truck, and it features a built-in radiator protection bar.

*Reduces headroom by 1" (25mm)

LOW EMISSION DIESEL ENGINE

UniCarriers' global commitment to preserving and protecting the environment is evident in our own GCT ZD30 low emission, 4-cylinder 'Advanced Turbo Diesel' (ATD) engine, offering improved fuel consumption and near elimination of particulate matter. The combination of advanced engine technology—electronic fuel injection, turbo charger, cooled exhaust gas recirculation, and diesel oxidation catalyst—results in high power and increased efficiency, with emission levels below EPA Tier 4 requirements. The ATD ZD30 provides low emissions without using a Diesel Particulate Filter (DPF), so regeneration is not necessary. The ZD30 engine includes an electronic controlled Quick Glow system for dependable cold weather starting.

ELECTRONIC CONTROLLED ENGINE TECHNOLOGY

The ZD30 'Advanced Turbo Diesel' (ATD) electronic fuel injected engine analyzes engine performance parameters and optimizes engine operation, resulting in enhanced productivity and lower fuel consumption. This system includes three main components: Engine Control Module (ECM), Vehicle Control Module (VCM), and Multifunction LCD Display.

The ECM responds to sensor input to control basic engine related functions, such as proper air/fuel ratio, turbo boost pressure, torque and speed, based on the requirements of the application. The VCM monitors a number of sensors to alert the operator of changing conditions via a full range of warning indicators located on the truck's LCD display. All communication among these components occurs through a Controller Area Network (CAN) system.

The ZD30 industrial engine is specifically designed and tested for industrial applications in order to deliver the power and torque to meet the needs of the application. As an added safeguard for your investment, the FK Series includes a protection and warning system for the engine and transmission, to reduce engine rpm in the event of excessive heat generation or loss of engine oil.

EASE OF MAINTENANCE

Tilt cylinders can be greased without removing any body panels. The diamond tread floorboard can be easily lifted off, promoting simple access to hydraulic and transmission components. Detachable side panels and a wide-open clamshell hood provide a roomy area for service technicians to perform their tasks. The three-piece reinforced overhead guard simplifies replacement of individual components if necessary, saving time and money. Plus an access door in the dash panel allows for quick and easy brake fluid checks.

A multi-function LCD display includes on-board diagnostics to keep service time low, with a programmable service reminder in order to stay current with periodic maintenance needs. Its display design provides the operator with excellent visibility and understanding of indicator lights.

DIMENSIONS

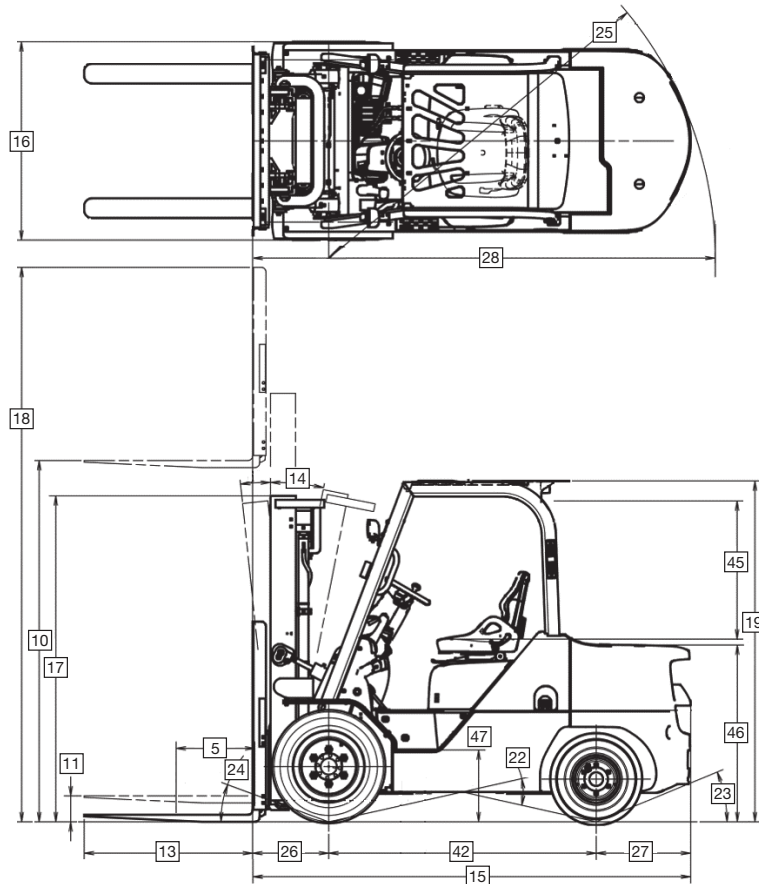

MAST SPECIFICATIONS & RATED CAPACITIES

Mast Name	Maximum Fork Height	Overall Height Lowered	Free Lift*	Tilt Angle Forward/Backward	Rated Capacity 24 in (600 mm) Load Center				
					PF40YD		PF50YD		
					Single Drive	Dual Drive	Single Drive	Dual Drive	
	in (mm)	in (mm)	in (mm)	degrees	lb (kg)		lb (kg)		
TWO STAGE (Wide view VM)	VM270	106.3 (2700)	73.8 (1875)	4.3 (110)	6/11	4000 (1800)	4000 (1800)	5000 (2250)	5000 (2250)
	VM300	118.1 (3000)	79.7 (2025)	4.3 (110)	6/11	4000 (1800)	4000 (1800)	5000 (2250)	5000 (2250)
	VM330	129.9 (3300)	85.6 (2175)	4.3 (110)	6/11	4000 (1800)	4000 (1800)	5000 (2250)	5000 (2250)
	VM350	137.8 (3500)	89.6 (2275)	4.3 (110)	6/11	4000 (1800)	4000 (1800)	5000 (2250)	5000 (2250)
	VM370	145.7 (3700)	93.5 (2375)	4.3 (110)	6/11	4000 (1800)	4000 (1800)	5000 (2250)	5000 (2250)
	VM400	157.5 (4000)	101.4 (2575)	4.3 (110)	6/11	4000 (1800)	4000 (1800)	5000 (2250)	5000 (2250)
	VM450	177.2 (4500)	111.2 (2825)	4.3 (110)	6/6	4000 (1800)	4000 (1800)	5000 (2250)	5000 (2250)
	VM500	196.9 (5000)	121.1 (3075)	4.3 (110)	6/6	3900 (1750)	3900 (1750)	4900 (2200)	4900 (2200)
	VM550	216.5 (5500)	132.9 (3375)	4.3 (110)	6/6	-	3650 (1650)	-	4600 (2050)
VM600	236.2 (6000)	142.7 (3625)	4.3 (110)	6/6	-	3500 (1550)	-	4450 (2000)	
TWO STAGE (Full free VFM)	VFM270	106.3 (2700)	73.8 (1875)	25.8 (655)	6/9	4000 (1800)	4000 (1800)	5000 (2250)	5000 (2250)
	VFM275	108.3 (2750)	74.8 (1900)	26.8 (680)	6/9	4000 (1800)	4000 (1800)	5000 (2250)	5000 (2250)
	VFM300	118.1 (3000)	79.7 (2025)	31.7 (805)	6/11	4000 (1800)	4000 (1800)	5000 (2250)	5000 (2250)
	VFM325	128.0 (3250)	84.6 (2150)	37.4 (950)	6/11	4000 (1800)	4000 (1800)	5000 (2250)	5000 (2250)
	VFM330	129.9 (3300)	85.6 (2175)	37.6 (955)	6/11	4000 (1800)	4000 (1800)	5000 (2250)	5000 (2250)
	VFM350	137.8 (3500)	89.6 (2275)	45.5 (1055)	6/11	4000 (1800)	4000 (1800)	5000 (2250)	5000 (2250)
	VFM370	145.7 (3700)	93.5 (2375)	45.3 (1150)	6/11	4000 (1800)	4000 (1800)	5000 (2250)	5000 (2250)
	VFM375	147.6 (3750)	94.5 (2400)	47.4 (1205)	6/11	3950 (1750)	4000 (1800)	4950 (2200)	5000 (2250)
	VFM400	157.5 (4000)	101.4 (2575)	53.3 (1355)	6/11	3950 (1750)	4000 (1800)	4950 (2200)	5000 (2250)
VFM450	177.2 (4500)	111.2 (2825)	63.2 (1605)	6/6	3950 (1750)	4000 (1800)	4950 (2200)	5000 (2250)	
THREE STAGE (Full free VFH)	VFH360	141.7 (3600)	69.9 (1775)	21.9 (555)	6/6	4000 (1800)	4000 (1800)	5000 (2250)	5000 (2250)
	VFH400	157.5 (4000)	74.8 (1900)	26.8 (680)	6/6	4000 (1800)	4000 (1800)	5000 (2250)	5000 (2250)
	VFH435	171.3 (4350)	79.7 (2025)	34.7 (805)	6/6	4000 (1800)	4000 (1800)	5000 (2250)	5000 (2250)
	VFH480	189.0 (4800)	85.6 (2175)	37.6 (955)	6/6	3850 (1700)	4000 (1800)	3950 (1750)	4950 (2200)
	VFH500	196.9 (5000)	89.6 (2275)	40.7 (1035)	6/6	3650 (1650)	3900 (1750)	3700 (1650)	4850 (2150)
	VFH550	216.5 (5500)	96.1 (2440)	48.0 (1220)	6/6	2950 (1300)	3750 (1700)	3650 (1650)	4500 (2000)
	VFH600	236.2 (6000)	103.3 (2625)	55.3 (1405)	6/6	2000 (900)	3400 (1500)	2100 (950)	4300 (1950)
	VFH650	255.9 (6500)	111.8 (2840)	63.6 (1615)	6/6	-	3250 (1450)	-	3400 (1500)
	VFH700	275.6 (7000)	120.5 (3060)	72.2 (1835)	6/6	-	2550 (1150)	-	2600 (1150)

*With LBR

MAIN TRUCK SPECIFICATIONS

CHARACTERISTICS	1 Manufacturer's Name			UniCarriers	UniCarriers	
	2 Model		Model designation	PF40YD	PF50YD	
	3		Long model code	FHD20T5V	FHD25T5V	
CHARACTERISTICS	4	Rated Load Capacity	lb (kg)	4000 (1800)	5000 (2250)	
	5	Load Center	Distance	24 (600)	24 (600)	
	6	Power Type		Diesel	Diesel	
	7	Operator Orientation		Sit	Sit	
	DIMENSIONS	8	Tire Type	Front & rear	Pneumatic	Pneumatic
		9	Wheels	Number (x=driven) front/rear	2 x / 2	2 x / 2
		10	Mast	Maximum fork height	129.9 (3300)	129.9 (3300)
11			Standard freelif	4.3 (110)	4.3 (110)	
12		Forks	Thickness & width	1.5 x 4 (40x100)	1.5 x 4 (40x100)	
13			Length	42 (1070)	42 (1070)	
14		Tilt Angle	Standard mast - fwd/back	6/11	6/11	
15		Overall Dimensions	Length (to face of forks)	102.8 (2610)	105.3 (2675)	
16			Width (single/dual tires)	45.3 (1150) / 64.6 (1640)	45.3 (1150) / 64.6 (1640)	
17			Mast lowered (OHL)	85.6 (2175)	85.6 (2175)	
18			Mast extended with LBR	173.4 (4405)	173.4 (4405)	
19			Height - top of OHG	84.1 (2135)	84.1 (2135)	
20			Height - top of standard LBR	48.0 (1220)	48.0 (1220)	
21			Width - standard carriage	42.3 (1075)	42.3 (1075)	
22		Grade Clearance	Ramp breakover angle	40	40	
23			Departure angle	44	44	
24			Approach angle	28	28	
25		Turning Radius	Minimum outside	90.7 (2305)	92.9 (2360)	
26		Overhang	Front	18.5 (470)	18.5 (470)	
27			Rear	19.3 (490)	21.9 (555)	
28		Min Right Angle Stack	Add load length & clearance	109.2 (2775)	111.4 (2830)	
PERFORMANCE		29	Speeds Maximum	Travel - forward or reverse	11.5 (18.5)	11.5 (18.5)
		30		Lift - full/empty	129.9/139.8(660/710)	129.9/139.8(660/710)
		31		Lowering - full/empty	98.4 (500)	98.4 (500)
		32	Drawbar Pull Max	Full load	5845 (2651)	5800 (2630)
		33		Empty	2220 (1006)	2120 (961)
		34	Gradeability Max (1.2 mph)	Full/empty	45 / 30	38 / 26
WEIGHT		35	Truck Weight	Standard truck - no load	7795 (3535)	8560 (3880)
	36	Weight Distribution	Front axle - empty	3775 (1712)	3600 (1633)	
	37		Rear axle - empty	4020 (1823)	4960 (2250)	
	38		Front axle - with rated load	10390 (4713)	11870 (5384)	
	39		Rear axle - with rated load	1400 (635)	1690 (760)	
CHASSIS & WHEELS	40	Tire Size	Front - single tire	7.00-12-12PR	7.00-12-12PR	
	41		Rear	6.00-9-10PR	6.00-9-10PR	
	42	Wheelbase		65 (1650)	65 (1650)	
	43	Tread - Center of Tire	Front / rear	37.8/38.4 (960/975)	37.8/38.4 (960/975)	
	44		Front - dual tires	47.5 (1205)	47.5 (1205)	
	45	Headroom	SIP to bottom of OHG	38.5 (980)	38.5 (980)	
	46	Counterweight Height		43.1 (1095)	43.1 (1095)	
	47	Step Height		16.7 (425)	16.7 (425)	
	48	Ground Clearance	Under mast	4.1 (105)	4.1 (105)	
	49		Under power unit	6.9 (175)	6.9 (175)	
	50		Under frame (WB center)	5.9 (150)	5.9 (150)	
	51	Service Brake	Type	Drum and Shoe	Drum and Shoe	
	52	Parking Brake	Type	Hand	Hand	
	53	Steering	Type	Full Hydraulic	Full Hydraulic	
DRIVE LINE	54	Engine	Model	GCT ZD30	GCT ZD30	
	55	Rated Output	SAE gross	63 (47) @ 2400	63 (47) @ 2400	
	56	Rated Torque	SAE gross	157.8 (214) @ 1900	157.8 (214) @ 1900	
	57	Displacement		180 (2953)	180 (2953)	
	58	Transmission	Type	Automatic	Automatic	
	59		Number speeds - fwd/rev	1/1	1/1	

MAIN TRUCK SPECIFICATIONS

CHARACTERISTICS	1			UniCarriers	UniCarriers			
	2			PF60YD	PF70YD			
	3			FHD30T5V	FHD35T5SV			
CHARACTERISTICS	4		Rated Load Capacity	lb (kg)	6000 (2700)	7000 (3150)		
	5		Load Center	Distance	in (mm)	24 (600)	24 (600)	
	6		Power Type		Diesel	Diesel		
	7		Operator Orientation		Sit	Sit		
	8		Tire Type	Front & rear	Pneumatic	Pneumatic		
	9		Wheels	Number (x=driven) front/rear	2 x / 2	2 x / 2		
	10		Mast	Maximum fork height	in (mm)	129.9 (3300)	129.9 (3300)	
DIMENSIONS	11		Standard freelif		in (mm)	6.5 (165)	6.5 (165)	
	12		Forks	Thickness & width	in (mm)	2 x 5 (50x122)	2 x 5 (50x122)	
	13		Length		in (mm)	42 (1070)	42 (1070)	
	14		Tilt Angle	Standard mast - fwd/back	degree	6/11	6/11	
	15		Overall Dimensions	Length (to face of forks)	in (mm)	109.6 (2785)	112.8 (2865)	
	16			Width (single/dual tires)	in (mm)	49.2 (1250) / 65.6 (1665)	50.4 (1280) / 69.9 (1775)	
	17		Mast lowered (OHL)		in (mm)	87.2 (2220)	89.8 (2280)	
	18		Mast extended with LBR		in (mm)	180.3 (4580)	180.3 (4580)	
	19		Height - top of OHG		in (mm)	85.0 (2160)	85.0 (2160)	
	20		Height - top of standard LBR		in (mm)	48.0 (1220)	48.0 (1220)	
	21		Width - standard carriage		in (mm)	44.7 (1136)	44.7 (1136)	
	22		Grade Clearance	Ramp breakover angle	tan (%)	46	51	
	23		Departure angle		tan (%)	40	38	
	24		Approach angle		tan (%)	36	36	
	25		Turning Radius	Minimum outside	in (mm)	96.7 (2455)	99.2 (2520)	
	26		Overhang	Front	in (mm)	19.1 (485)	19.5 (495)	
	27			Rear	in (mm)	23.6 (600)	26.4 (670)	
	28		Min Right Angle Stack	Add load length & clearance	in (mm)	115.8 (2940)	118.7 (3015)	
	PERFORMANCE	29		Speeds Maximum	Travel - forward or reverse	mph (kmh)	11.2 (18)	11.2 (18)
		30		Lift - full/empty		fpm (mm/sec)	106.3/114.2 (540/580)	90.6/96.5 (460/490)
		31		Lowering - full/empty		fpm (mm/sec)	98.4 (500)	82.7/70.9 (420/360)
32		Drawbar Pull Max	Full load	lb (kg)	5735 (2601)	5365 (2434)		
33			Empty	lb (kg)	2345 (1064)	2390 (1084)		
34		Gradeability Max (1.2 mph)	Full/empty	tan (%)	31 / 25	26 / 23		
WEIGHT	35		Truck Weight	Standard truck - no load	lb (kg)	9745 (4420)	10815 (4906)	
	36		Weight Distribution	Front axle - empty	lb (kg)	3940 (2633)	4030 (1828)	
	37			Rear axle - empty	lb (kg)	5805 (2633)	6790 (3080)	
	38		Front axle - with rated load		lb (kg)	13805 (6263)	15500 (7031)	
	39		Rear axle - with rated load		lb (kg)	1940 (880)	2245 (1018)	
CHASSIS & WHEELS	40		Tire Size	Front - single tire		28x9-15-12PR	250-15-16PR	
	41		Rear			6.50-10-10PR	6.50-10-12PR	
	42		Wheelbase		in (mm)	66.9 (1700)	66.9 (1700)	
	43		Tread - Center of Tire	Front / rear	in (mm)	40.6/38.6 (1030/980)	41.7/38.6 (1060/980)	
	44			Front - dual tires	in (mm)	47.7 (1210)	50.6 (1285)	
	45		Headroom	SIP to bottom of OHG	in (mm)	38.5 (980)	38.5 (980)	
	46		Counterweight Height		in (mm)	44.3 (1125)	44.7 (1135)	
	47		Step Height		in (mm)	17.9 (455)	18.3 (465)	
	48		Ground Clearance	Under mast	in (mm)	5.3 (135)	5.5 (140)	
	49			Under power unit	in (mm)	8.1 (205)	8.5 (215)	
	50			Under frame (WB center)	in (mm)	7.1 (180)	7.5 (190)	
	51		Service Brake	Type		Drum and Shoe	Drum and Shoe	
	52		Parking Brake	Type		Hand	Hand	
	53		Steering		Type	Full Hydraulic	Full Hydraulic	
DRIVE LINE	54		Engine	Model		GCT ZD30	GCT ZD30	
	55		Rated Output	SAE gross	hp (kW) @ rpm	63 (47) @ 2400	63 (47) @ 2400	
	56		Rated Torque	SAE gross	ft-lb (Nm) @ rpm	157.8 (214) @ 1900	157.8 (214) @ 1900	
	57		Displacement		cu in (cm ³)	180 (2953)	180 (2953)	
	58		Transmission		Type	Automatic	Automatic	
	59		Number speeds - fwd/rev			1/1	1/1	

MAST SPECIFICATIONS & RATED CAPACITIES

Mast Name		Maximum Fork Height	Overall Height Lowered	Free Lift*	Tilt Angle Forward/Backward	Rated Capacity 24 in (600 mm) Load Center	
						PF60YD	
						Single Drive	Dual Drive
		in (mm)	in (mm)	in (mm)	degrees	lb (kg)	lb (kg)
TWO STAGE (Wide view VM)	VM270	106.3 (2700)	75.6 (1920)	6.5 (165)	6/11	6000 (2700)	6000 (2700)
	VM300	118.1 (3000)	81.5 (2070)	6.5 (165)	6/11	6000 (2700)	6000 (2700)
	VM330	129.9 (3300)	87.2 (2220)	6.5 (165)	6/11	6000 (2700)	6000 (2700)
	VM350	137.8 (3500)	91.3 (2320)	6.5 (165)	6/11	6000 (2700)	6000 (2700)
	VM370	145.7 (3700)	95.3 (2420)	6.5 (165)	6/11	6000 (2700)	6000 (2700)
	VM400	157.5 (4000)	103.2 (2620)	6.5 (165)	6/11	6000 (2700)	6000 (2700)
	VM450	177.2 (4500)	113.0 (2870)	6.5 (165)	6/6	6000 (2700)	6000 (2700)
	VM500	196.9 (5000)	128.8 (3120)	6.5 (165)	6/6	5900 (2650)	5900 (2650)
	VM550	216.5 (5500)	134.7 (3420)	6.5 (165)	6/6	–	5500 (2450)
VM600	236.2 (6000)	144.5 (3670)	6.5 (165)	6/6	–	5300 (2400)	
TWO STAGE (Full free VFM)	VFM270	106.3 (2700)	75.6 (1920)	27.4 (695)	6/9	6000 (2700)	6000 (2700)
	VFM275	108.3 (2750)	76.6 (1945)	28.3 (720)	6/9	6000 (2700)	6000 (2700)
	VFM300	118.1 (3000)	81.5 (2070)	33.3 (845)	6/11	6000 (2700)	6000 (2700)
	VFM325	128.0 (3250)	86.4 (2195)	38.2 (970)	6/11	6000 (2700)	6000 (2700)
	VFM330	129.9 (3300)	87.4 (2220)	39.2 (995)	6/11	6000 (2700)	6000 (2700)
	VFM350	137.8 (3500)	91.3 (2320)	43.1 (1095)	6/11	6000 (2700)	6000 (2700)
	VFM370	145.7 (3700)	95.3 (2420)	47.0 (1195)	6/11	6000 (2700)	6000 (2700)
	VFM375	147.6 (3750)	96.3 (2445)	48.0 (1220)	6/11	5950 (2650)	6000 (2700)
	VFM400	157.5 (4000)	103.1 (2620)	54.9 (1395)	6/11	5950 (2650)	6000 (2700)
VFM450	177.2 (4500)	113.0 (2870)	64.8 (1645)	6/6	5950 (2650)	6000 (2700)	
THREE STAGE (Full free VFH)	VFH360	141.7 (3600)	71.7 (1820)	23.4 (595)	6/6	6000 (2700)	6000 (2700)
	VFH400	157.5 (4000)	76.6 (1945)	28.3 (720)	6/6	6000 (2700)	6000 (2700)
	VFH435	171.3 (4350)	81.5 (2070)	33.3 (845)	6/6	6000 (2700)	6000 (2700)
	VFH480	189.0 (4800)	87.4 (2220)	39.2 (995)	6/6	6000 (2700)	6000 (2700)
	VFH500	196.9 (5000)	91.3 (2320)	43.1 (1095)	6/6	5600 (2500)	5900 (2650)
	VFH550	216.5 (5500)	97.8 (2485)	49.6 (1260)	6/6	4200 (1900)	5600 (2500)
	VFH600	236.2 (6000)	105.1 (2670)	56.9 (1445)	6/6	3100 (1400)	5100 (2300)
	VFH650	255.9 (6500)	113.6 (2885)	65.4 (1660)	6/6	–	3450 (1550)
	VFH700	275.6 (7000)	122.2 (3105)	74.0 (1880)	6/6	–	2950 (1300)

*Free Lift with LBR.

Mast Name		Maximum Fork Height	Overall Height Lowered	Free Lift*	Tilt Angle Forward/Backward	Rated Capacity 24 in (600 mm) Load Center	
						PF70YD	
						Single Drive	Dual Drive
		in (mm)	in (mm)	in (mm)	degrees	lb (kg)	lb (kg)
TWO STAGE (Wide view VM)	VM270	106.3 (2700)	78.0 (1980)	6.5 (165)	6/9	7000 (3150)	7000 (3150)
	VM300	118.1 (3000)	83.9 (2130)	6.5 (165)	6/11	7000 (3150)	7000 (3150)
	VM330	129.9 (3300)	89.8 (2280)	6.5 (165)	6/11	7000 (3150)	7000 (3150)
	VM350	137.8 (3500)	93.7 (2380)	6.5 (165)	6/11	7000 (3150)	7000 (3150)
	VM370	145.7 (3700)	97.6 (2480)	6.5 (165)	6/11	7000 (3150)	7000 (3150)
	VM400	157.5 (4000)	105.5 (2680)	6.5 (165)	6/11	6900 (3100)	7000 (3150)
	VM450	177.2 (4500)	115.4 (2930)	6.5 (165)	6/6	6800 (3050)	6900 (3100)
	VM500	196.9 (5000)	125.2 (3180)	6.5 (165)	6/6	6600 (2950)	6700 (3000)
	VM550	216.5 (5500)	137.0 (3480)	6.5 (165)	6/6	–	6400 (2900)
VM600	236.2 (6000)	146.9 (3730)	6.5 (165)	6/6	–	6150 (2750)	
TWO STAGE (Full free VFM)	VFM270	106.3 (2700)	78.0 (1980)	29.7 (755)	6/9	7000 (3150)	7000 (3150)
	VFM275	108.3 (2750)	78.9 (2005)	30.7 (780)	6/9	7000 (3150)	7000 (3150)
	VFM300	118.1 (3000)	83.9 (2130)	35.6 (905)	6/11	7000 (3150)	7000 (3150)
	VFM325	128.0 (3250)	88.8 (2255)	40.6 (1030)	6/11	7000 (3150)	7000 (3150)
	VFM330	129.9 (3300)	89.8 (2280)	41.5 (1055)	6/11	7000 (3150)	7000 (3150)
	VFM350	137.8 (3500)	93.7 (2380)	45.5 (1155)	6/11	7000 (3150)	7000 (3150)
	VFM370	145.7 (3700)	97.6 (2480)	49.4 (1255)	6/11	7000 (3150)	7000 (3150)
	VFM375	147.6 (3750)	98.6 (2505)	50.4 (1280)	6/11	6900 (3100)	7000 (3150)
	VFM400	157.5 (4000)	105.5 (2680)	57.3 (1455)	6/11	6900 (3100)	7000 (3150)
VFM450	177.2 (4500)	115.4 (2930)	67.1 (1705)	6/6	6800 (3050)	6900 (3100)	
THREE STAGE (Full free VFH)	VFH360	141.7 (3600)	74.0 (1880)	25.0 (655)	6/6	7000 (3150)	7000 (3150)
	VFH400	157.5 (4000)	78.9 (2005)	30.7 (780)	6/6	7000 (3150)	7000 (3150)
	VFH435	171.3 (4350)	83.9 (2130)	35.6 (905)	6/6	6800 (3050)	6800 (3050)
	VFH480	189.0 (4800)	89.8 (2280)	41.5 (1055)	6/6	6600 (2950)	6600 (2950)
	VFH500	196.9 (5000)	93.7 (2380)	45.5 (1155)	6/6	6300 (2850)	6500 (2900)
	VFH550	216.5 (5500)	100.2 (2545)	52.0 (1320)	6/6	5300 (2400)	6050 (2700)
	VFH600	236.2 (6000)	107.5 (2730)	59.3 (1505)	6/6	3500 (1550)	5750 (2600)
	VFH650	255.9 (6500)	115.9 (2945)	67.7 (1720)	6/6	–	3500 (1550)
	VFH700	275.6 (7000)	124.6 (3165)	76.4 (1940)	6/6	–	3000 (1350)

*Free Lift with LBR.

STANDARD EQUIPMENT

- UniCarriers' own GCT ZD30 low emission, 4-cylinder, 3.0L industrial engine
- 'Advanced Turbo Diesel' (ATD) engine design
- Computer controlled electronic engine system with common rail fuel injection
- Cooled Exhaust Gas Recirculation (EGR) and Diesel Oxidation Catalyst (DOC)
- Engine/transmission protection and warning system
- Operator Presence System
- Full suspension vinyl seat with operator restraint system
- Parking brake with warning buzzer
- Horn and back-up alarm
- Rubber floor mat
- Tilt-adjustable steering wheel
- Multi-function LCD:
 - Hour meter, Clock, Calendar & Operator PIN access
 - Onboard diagnostics and programmable service reminders
 - Warning lights & engine coolant temperature gauge
 - Air cleaner service indicator
 - Low engine oil pressure warning
 - Low coolant & brake fluid level warning indicators
 - Low fuel warning indicator & fuel gauge
- Single speed powershift transmission with full floating powertrain
- Hydrostatic power steering
- Single lift/tilt hydraulic control lever
- High air intake system with large cyclone air filter
- Overhead guard mounted LED headlights
- 3-piece reinforced overhead guard
- Power/Economy acceleration mode

OPTIONAL EQUIPMENT

- High/Low travel speed control settings
- Separate lift & tilt hydraulic control levers
- Standard or wide carriage
- Integral or hang-on side shifter
- 4-spool hydraulic valve
- Internal hydraulic hose reeving - single or dual
- Solid or dual drive pneumatic tires
- Anti-Dust, Low Noise, or Corrosion Resistance packages
- Tilt cylinder boots or covers
- Vertical exhaust
- Open core straight fin radiator
- Radiator screen
- Air intake pre-cleaner
- Rear LED combination light package
- Rear LED work light
- Rear strobe light
- Rear view mirrors
- Fire extinguisher
- Polycarbonate overhead guard rain cover
- Orange seat belt



SS-FK 06-2016 Printed in U.S.A.

UniCarriers® is a registered trademark of UniCarriers Corporation. UniCarriers Americas Corporation reserves the right to make product changes relating to colors, equipment, specifications or available options without notice. For more information, contact your UniCarriers representative.

